

1. OPERATING TEMPERATURE: -55°C TO 105°C
2. MATERIAL: HOUSING, NYLON 6/6, UL 94V-0, BLACK CONTACT, 0.30 [.012] THICK COPPER ALLOY
3. FINISH: BRIGHT TIN-LEAD PLATE 0.00203-0.00508 [.000080-.000200"] THICK OR MATTE WHISKER MITIGATED TIN 0.00203 [.000080] MIN THICKNESS OVER NICKEL UNDERPLATE.
4. LUBRICATED WITH AMP ANTI-FRETTING LUBRICANT.
5. IDENTIFICATION NUMBER FOR FIRST CIRCUIT.
6. WIRE GAUGE IDENTIFICATION
7. DIMENSIONS IN BRACKETS ARE IN INCHES.
8. CONTACT MUST ACCEPT 1.14±0.03 [.045±.001] SQUARE POST AND REMAINED LOCKED IN POSITION.

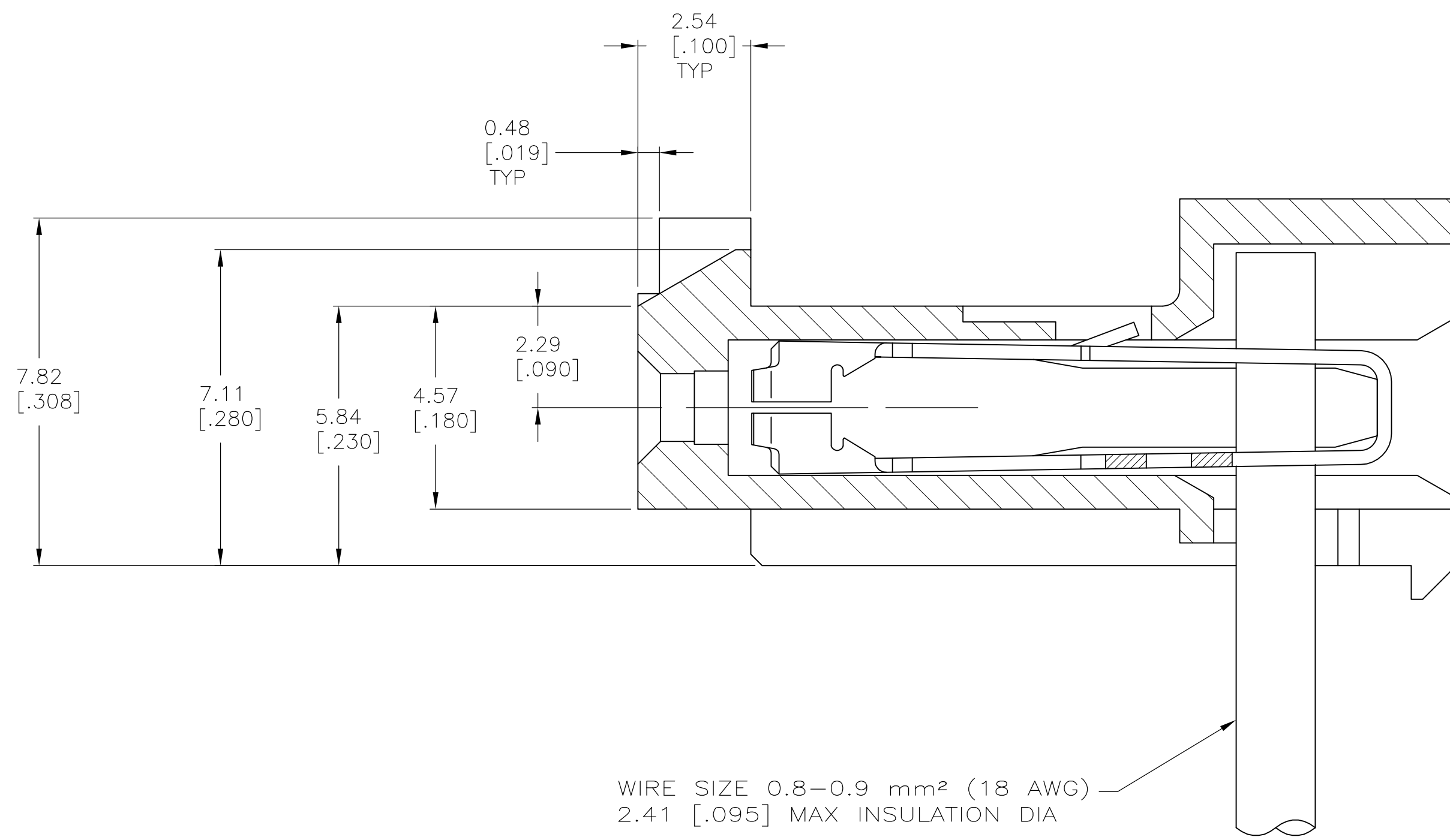

TIN	47.55±0.30	[1.872±.012]	12	4-644381-2
TIN	43.59±0.30	[1.716±.012]	11	4-644381-1
TIN	39.62±0.30	[1.560±.012]	10	4-644381-0
TIN	35.66±0.30	[1.404±.012]	9	3-644381-9
TIN	31.70±0.30	[1.248±.012]	8	3-644381-8
TIN	27.74±0.30	[1.092±.012]	7	3-644381-7
TIN	23.77±0.30	[.936±.012]	6	3-644381-6
TIN	19.81±0.30	[.780±.012]	5	3-644381-5
TIN	15.85±0.15	[.624±.006]	4	3-644381-4
TIN	11.89±0.15	[.468±.006]	3	3-644381-3
TIN	7.92±0.15	[.312±.006]	2	3-644381-2
TIN-LEAD	47.55±0.30	[1.872±.012]	12	1-644381-2
TIN-LEAD	43.59±0.30	[1.716±.012]	11	1-644381-1
TIN-LEAD	39.62±0.30	[1.560±.012]	10	1-644381-0
TIN-LEAD	35.66±0.30	[1.404±.012]	9	644381-9
TIN-LEAD	31.70±0.30	[1.248±.012]	8	644381-8
TIN-LEAD	27.74±0.30	[1.092±.012]	7	644381-7
TIN-LEAD	23.77±0.30	[.936±.012]	6	644381-6
TIN-LEAD	19.81±0.30	[.780±.012]	5	644381-5
TIN-LEAD	15.85±0.15	[.624±.006]	4	644381-4
TIN-LEAD	11.89±0.15	[.468±.006]	3	644381-3
TIN-LEAD	7.92±0.15	[.312±.006]	2	644381-2
FINISH	A		NO OF CKTS	PART NO

METRIC

THIS DRAWING IS A CONTROLLED DOCUMENT. DWN S. CARPENTER 14 AUG 2003  
 CHK D. BOSSI 14 AUG 2003  
 APVD D. BOSSI 14 AUG 2003

Tyco Electronics Corporation  
 Harrisburg, Pa 17105-3608

MTA-156 CONNECTOR ASSEMBLY, QUAD, 18 AWG, WITH LOCKING RAMP.

108-1219  
 114-1048

SIZE A1 CAGE CODE 00779 DRAWING NO 644381  
 WEIGHT -

CUSTOMER DRAWING SCALE 10:1 SHEET 1 OF 1 REV F